

RevNo	Revision note	Date	Signature	Checked
-------	---------------	------	-----------	---------

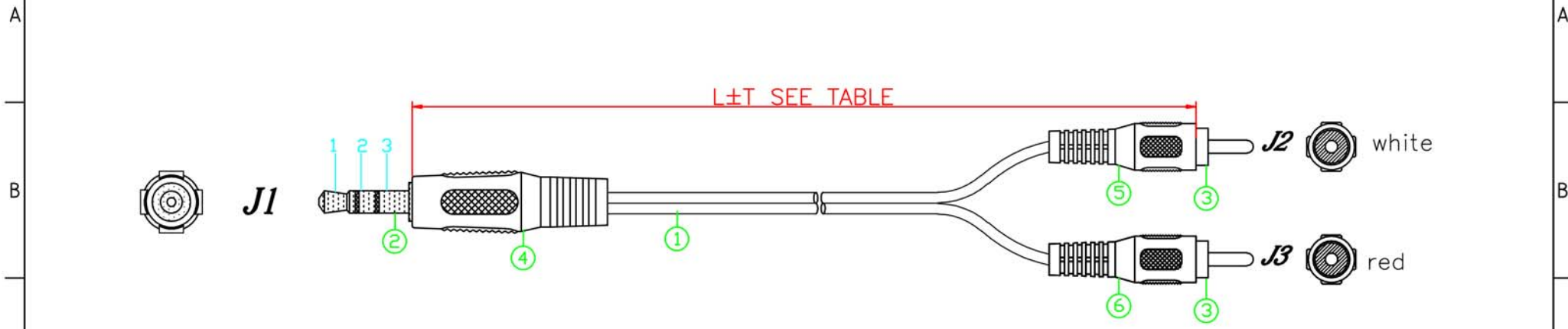

P/N	L/(M)	T/(MM)
23-1020	2	30
23-1030	3	45
23-1050	5	75
23-1100	10	150
23-1150	15	200
23-1200	20	250

NOTES:

- 1:100% short,open and miss wire test.
- 2:ROHS & REACH Compliant

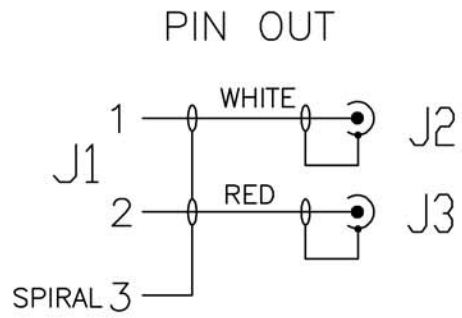

NO.	MATERIAL	DESCRIPTION	QTY.	UNIT
⑥	OUTER MOULDED	RED 45P PVC	0.010	KG
⑤	OUTER MOULDED	WHITE 45P PVC	0.010	KG
④	OUTER MOULDED	BLACK 45P PVC	0.010	KG
③	CONNECTOR	RCA TUBULAR MALE:SOLDER TYPE,WHITE INSULATOR,GOLD PLATED.	2	PCS
②	CONNECTOR	3.5/M STEREO PLUG SOLDER TYPE,BLACK INSULATOR,GOLD PLATED.	1	PCS
①	CABLE	(10/0.1CCS*2C+S/28*0.1CCS)*2,JACKET:BLACK PVC,OD:2.8*5.6±0.15MM	L	M

Ltemref	Quantity	Title/Name,designation,material,dimension etc			Article No./Reference	
Designed by	Checked by	Approved by - date	File name	Date	Scale	
		JUL 27,2015	ST3.5M-2RCA	JUL 27,2015	FREE	
ANGLE:		ST3.5M-2RCA CABLE,BLACK				
UNIT:MM		23-1020,23-1030,23-1050	Edition	Sheet		
		23-1100,23-1150,23-1200	1	1/1		