

Ltemref	Quantity	Title/Name, designation, material, dimension etc			Article NO./Reference	
Designed by FLY	Checkde by HELEN	Approved by - date 2025. 09. 28	File name	Date 2025. 09. 28	Scale FREE	
ANGLE:					20-0015	Edition 1
UNIT:MM					Sheet 1/3	

②	20-0015-3	HDMI2. 1 AM-AM	1	PCS
①	20-0015-1/2	HDMI2. 1 AM-AF+PANEL	1	PCS
NO.	MATERIAL	DESCRIPTION	QTY.	UNIT

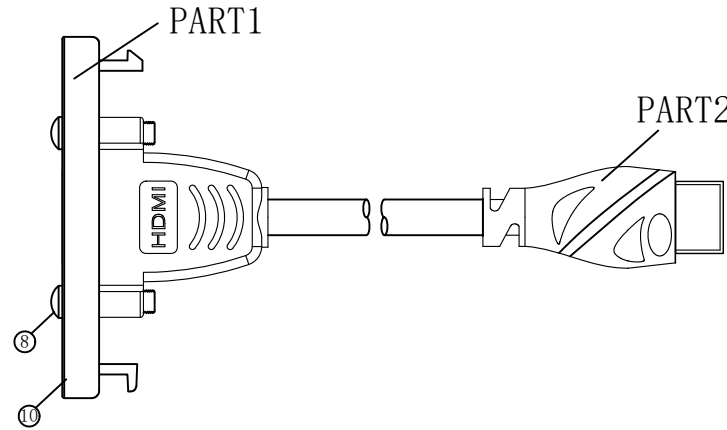

- A. Electronic Tests:
1. Open/Short/Intermittence: 100%
 2. Hi-Pot: AC 150V 0.01S 1mA
 3. Insulation Resistance: DC 300V 0.01S 10MΩ Min
 4. Conductive Resistance: 2Ω Max
- B. Functional Test:
- The set supports 7680*4320@60HZ or 3840*2160@120Hz video resolution
- C. Face plate color:RAL9003

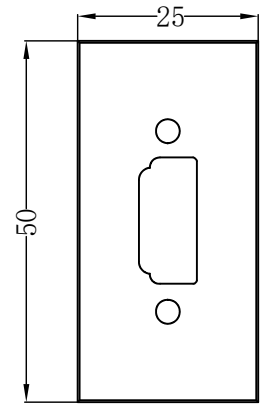
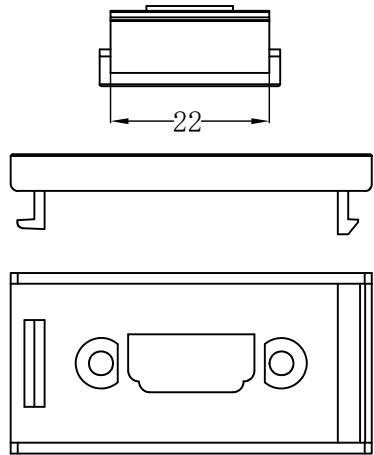

PART1

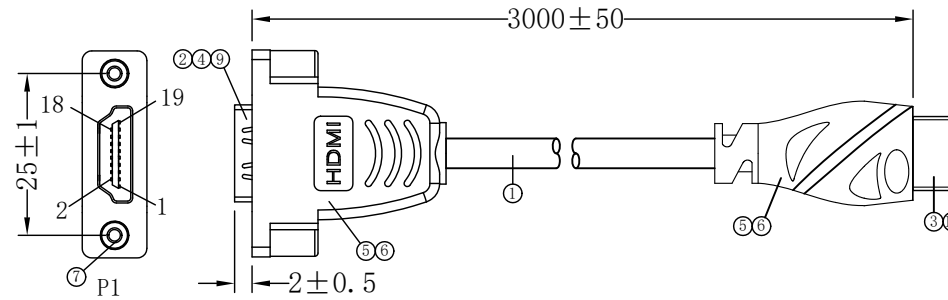

PART2

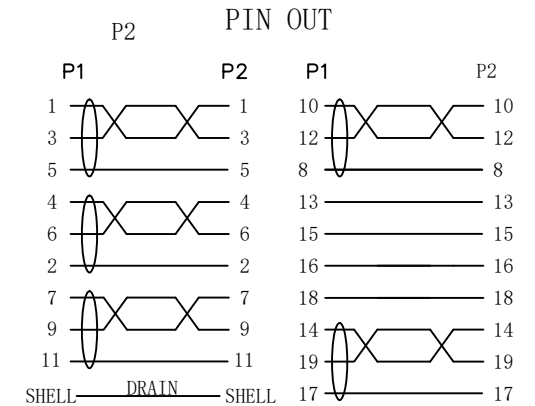
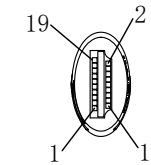

①	PANEL	ABS PANEL FOR HDMI AF, 50*25mm, Color:RAL9003	1	PCS
⑩	DUST CAP	HDMI A MALE DUST CAP	1	PCS
⑨	COPPER FOIL	DOUBLE SIDED CONDUCTIVE COPPER FOIL W=18MM	2	PCS
⑧	PHILIPS SCREW	PHILLIPS SCREW, #4-40, NI PLATED, L=14.5MM	2	PCS
⑦	EMBEDED NUT	SHOULDER SCREW, #4-40, φ4.5, L=10MM, CHAMFERED ENDS, NICKEL PLATED	2	PCS
⑥	MOLDING	45P BLACK PVC		G
⑤	MOLDING	LDPE MG70		G
④	CONNECTOR SHEATH	HDMI TYPE A FEMALE PLUG, SHORT BODY, BLACK BOOT, L=8.5MM	1	PCS
③	CONNECTOR	HDMI 19P A MALE, GOLD PLATED PIN, BLACK INSULATION, GOLD PLATED SHELL+INTEGRATED TINPLATE	1	PCS
②	CONNECTOR	HDMI 19P A FEMALE, GOLD PLATED PIN, BLACK INSULATION, GOLD PLATED SHELL	1	PCS
①	CABLE	HDMI2.1 [(1/0.34BC)*2C+D(1/0.254TC)+AL-FOIL]*5C+(1/0.25BC)*4C+AL-FOIL+D(1/0.25BC)+B(16/10/0.12 AL-Mg), BLACK PVC JACKET, OD:7.3±0.2MM MARKING:Ultra High Speed HDMI™ Cable with Etherne	3000	MM
NO.	MATERIAL	DESCRIPTION	QTY.	UNIT

Ltemref	Quantity	Title/Name, designation, material, dimension etc			Article NO./Reference	
Designed by FLY	Checkde by HELEN	Approved by - date 2025.09.28	File name	Date 2025.09.28	Scale FREE	
ANGLE:				HDMI2.1 AM-AF+PANEL		
UNIT:MM				20-0015-1/2	Edition 1	Sheet 2/3

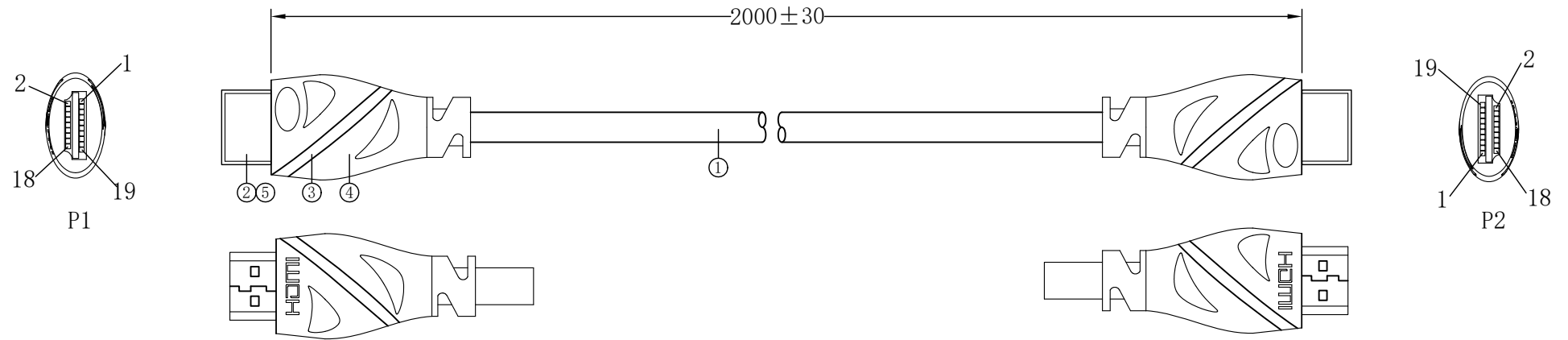

PIN OUT

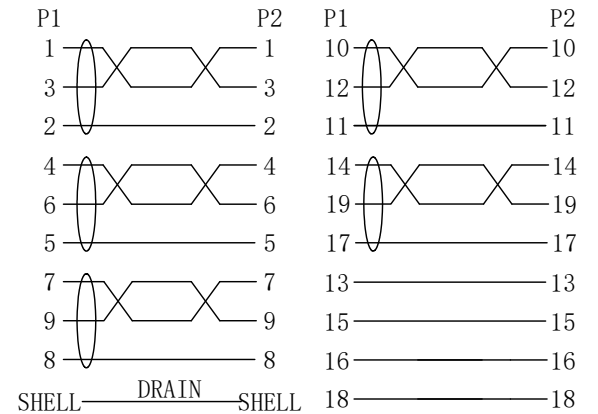

A. Electronic Tests:

1. Open/Short/Intermittence: 100%
2. Hi-Pot: AC 150V 0.01S 1mA
3. Insulation Resistance: DC 300V 0.01S 10MΩ Min
4. Conductive Resistance: 2Ω Max

B. Functional Test:

1. The set supports 7680*4320@60HZ or 3840*2160@120Hz video resolution

⑤	DUST CAP	HDMI A MALE DUST CAP	2	PCS
④	MOLDED	45P BLACK PVC		G
③	MOLDED	LDPE		G
②	CONNECTOR	HDMI 19P A MALE, GOLD PLATED PIN, BLACK INSULATION, GOLD PLATED SHELL+INTEGRATED TINPLATE	2	PCS
①	CABLE	HDMI2.1 [(1/0.34BC)*2C+D(1/0.254TC)+AL-FOIL]*5C+(1/0.25BC)*4C+AL-FOIL+D(1/0.25BC)+B(16/10/0.12 AL-Mg), BLACK PVC JACKET, OD:7.3±0.2MM MARKING:Ultra High Speed HDMI™ Cable with Etherne	2000	MM
NO.	MATERIAL	DESCRIPTION	QTY.	UNIT

Ltemref	Quantity	Title/Name, designation, material, dimension etc			Article NO./Reference	
Designed by FLY	Checkde by HELEN	Approved by - date 2025. 09. 26	File name	Date 2025. 09. 26	Scale FREE	
ANGLE:				HDMI2.1 AM-AM		
UNIT:MM				20-0015-3	Edition 1	Sheet 3/3